

ERJ 135/145 SEALED LEAD ACID BATTERY

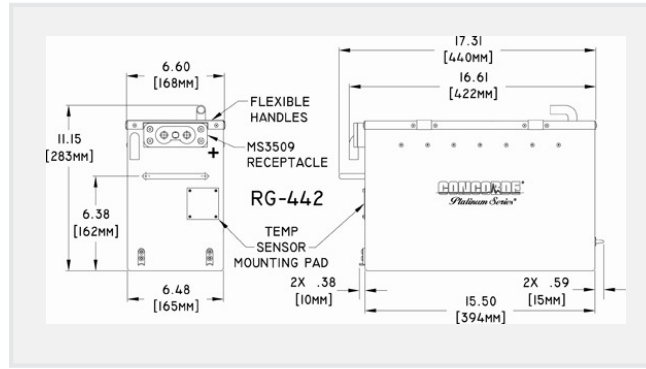

Replace your ERJ 135/145 batteries with higher performance and lower maintenance costs.

C&L, in partnership with Concorde Battery Corporation, offers the Concorde SLA (Sealed Lead Acid) Battery for the ERJ 135/145 Aircraft. The non-hazardous SLA batteries are a maintenance-free battery, as they can directly replace existing Ni-cad batteries and offer superior hot and cold-weather performance and the ability to recover from deep discharge. With this battery, you can expect significant cost savings on maintenance, shipping, installation, and operations.

Introduction to the SLA Battery Maintenance Schedule:

- Drop in replacement
- Lower cost of acquisition
- Reduced cost per flight hour
- No memory effect, cycling requirements, or thermal runaway
- Ship hazmat exempt
- Lead Acid Batteries are 100% recyclable
- Made in USA
- Dual purpose – emergency or main starting
- Factory tested – assures airworthiness & installation readiness
- Fire resistant aluminum cover
- Maintenance free with no water replenishment is required, ever
- Superior starting power in hot and cold climates

Specifications:

Part Number	RG-442
Size	11.15 x 6.60 x 17.31" max
Rated Capacity C1 in Ah	44 Ah
Qualification	STC ST01520WI
Weight	86 lb / 39 KG
Nominal Voltage	24V
Transportation	Non-haz & unrestricted when securely packed & protected against short circuit



inquiries@cla.aero

North America +1 207 217 6050

Latin America / Caribbean +1 207 217 6085

Europe / Africa +44 (0) 1622 960 117

Asia / Australia +61 (0)7 3354 8100